

PERMIT EXPIRES TWO (2) YEARS FROM DATE OF ISSUANCE
ONE SIX (6) MONTH EXTENSION MAY BE GRANTED PRIOR TO EXPIRATION DATE

APPLICATION FOR BUILDING / DEMOLITION PERMIT

VILLAGE OF NYACK
9 North Broadway · Nyack, NY 10960
Tel 845-358-4249 · Fax 845-358-0672 · Email: buildingdepartment@nyack-ny.gov

OFFICIAL USE ONLY

Land Use Board Review: ARB Planning ZBA

Permit No: _____ Application Date: 1/22/20

Fee Paid: \$940-BS - 100 ARB CHG 6247 Receipt #: _____

Inspector: _____ File #: _____

Permit Granted For: _____

Permit Denied For: _____

*Village Board, Planning Board, Zoning Board, Architectural Review Board decision date: _____

Property Location: 173 MAIN

Tax Map Designation: Section 66 Block 37-2-6 Lot 2

Property Owner: BISONI FAMILY LTD PARTNERSHIP Cell Phone: 914-490-9947

Address: 11 MARINE AVE WHITE PLAINS NY 10606 Home Phone: _____

Email: BISONI@PETERBISONI.COM Work Phone: 914-948-0605

Owner/Tenant: PIERMONT OYSTER HOUSE A & B GRILL INC Cell Phone: _____

Address: 173 MAIN ST. - NYACK NY 10960 Work Phone: _____

Email: DANNY_CROBERT@YAHOO.COM Cell Phone: 914-953-4697

Contact Person: DANNY CROBERT Phone: _____

Existing and / or proposed use of structure or land: BAR & GRILL

Project Description: MANUFACTURE & INSTALLATION OF AN AWNING TO COVER ROOF DECK.

Estimated Construction Value: \$ 46060.00

ROW SYDOROK

Architect / Engineer: MULTI-TECH ENGINEERING NYS Lic 079 HZ-1

Address: 284 WAVE DRIVE FORKED RIVER NJ 07731

Email: MULTI-TECH 417 @ GMAIL.COM Phone: 201-802-7546

Builder / General Contractor: GREGORY SHAGINN + SONS INC RC Lic #

Address: 18 N CENTRAL AVE HARTSANCE NY 10530

Email: GREG @ GSSAWNING.COM Phone: 914-949-9877

Plumber: RC Lic #

Address:

Email: Phone:

Heat / Cooling: RC Lic #

Address:

Email: Phone:

Electrician: RC Lic #

Address:

Email: Phone:

ZONING DISTRICT	BULK		
	Required	Existing	Proposed
Coverage			
Floor Area Ratio			
Lot Area			
Lot Width			
Street Frontage			
Front Yard Setback			
Side Yard Setback			
Total Side Yard Setback			
Rear Yard Setback			
Building Height - Feet			
Building Height - Number of Stories			
Residential Density			

Site Plan Application is also being made to the Planning Architectural Review Board

AFFIDAVIT

State of New York
County of Rockland) SS:
Village of Nyack

I, JOHN M GISOMP being duly sworn, depose and say that I am the owner (lessee, engineer, surveyor, architect, builder, or agent of the owner) in fee of the premises to which this application applies; that I (the applicant) is duly authorized to make this application and that the statements contained in the papers submitted herein are true to the best of his knowledge and belief, and that the work will be performed in the manner of set forth in the application and in the plans and specification filed therewith, and in accordance with State Uniform Building Code and all other applicable laws, ordinances and regulations of the municipality. I also declare that the structure or area described in this application will not be occupied or used until I have obtained a Certificate of Occupancy.

Signature and Mailing Address

[Signature]
11 HARDING AVE
WHITE PLAINS, NY
10606

SWORN to before me this

20th

day of

January

, 20 21.

Witness:

If not witnessed by Building Department personnel, Notary signature is required.

[Signature: Claudia Goldstein]

Notary Public

CLAUDIA GOLDSTEIN
Notary Public, State of New York
No. 01GO6250323
Qualified in Dutchess County
Term Expires October 24, 2015 23

APPLICATION INSTRUCTIONS

(See additional requirements when applying to land use Board)

1. In making this application, submit the following:
 - a. One (1) copy of this form.
 - b. Two (2) set of building plans for an internal building permit (only needing for building inspectors approval only or Ten (10) for Planning or Nine (9) for ARB or Nine (9) for ZBA
 - c. Two (2) copies of the plot plans.
 - d. Copy of Rockland County licenses. (For each trade)
 - e. Certificate of Liability, Certificate of Workman's Compensation, and Disability Benefits Insurance or Owner's affidavit. (For each trade)
2. Plot plans drawn to scale, shall show area, dimension, and location of lot; size and exact location of proposed structures, additions or alterations; all existing structures, all existing structures on lot; streets, curbs, sidewalks, parking spaces driveway; yards and setback; and such other information as may be necessary.
3. Building Plans drawn to scale shall show structural details, floor plans, elevation, plumbing, electrical, heating and ventilation details.
4. The NY.S. Department of Education Law states that a building permit may not be issued for any commercial structure or for a residence containing more than 1500 square feet of habitable space unless the building plans are prepared and signed by a New York State licensed engineer or registered architect.
5. No building permit of Certificate of Occupancy shall be issued by the Building Inspector unless all provisions of the Village of Nyack Zoning Code and the New York State Uniform Fire Prevention and Building Code are in compliance
6. Fees are based on cost of construction. (This office reserves the right to adjust any fee prior to issuing the Certificate of Occupancy if it is shown that the original fee was not sufficient to cover the actual cost.) Bills, invoices and other documentation must be submitted to substantiate both the Estimated Cost of Construction, as well as the Actual Cost of Construction.
7. Mandatory inspections are required for issuance of Certificate of Occupancy.
8. Underground utilities are required by the Zoning Code.
9. It shall be unlawful to use or permit the use of any building or premises or part thereof, hereafter created, erected, changed, converted or enlarged wholly or partly, in its use or structure, until a Certificate of Occupancy shall have been issued
10. This office reserves the right to require that the affidavit of compliance on the application for a Certificate of Occupancy be submitted and signed by the architect or engineer of record.
11. The building permit expires two years from the date of issuance. One six (6) month extension may be granted prior to be expiration date of the building permit (Renewal of all expired building permits requires a new application and fee.)



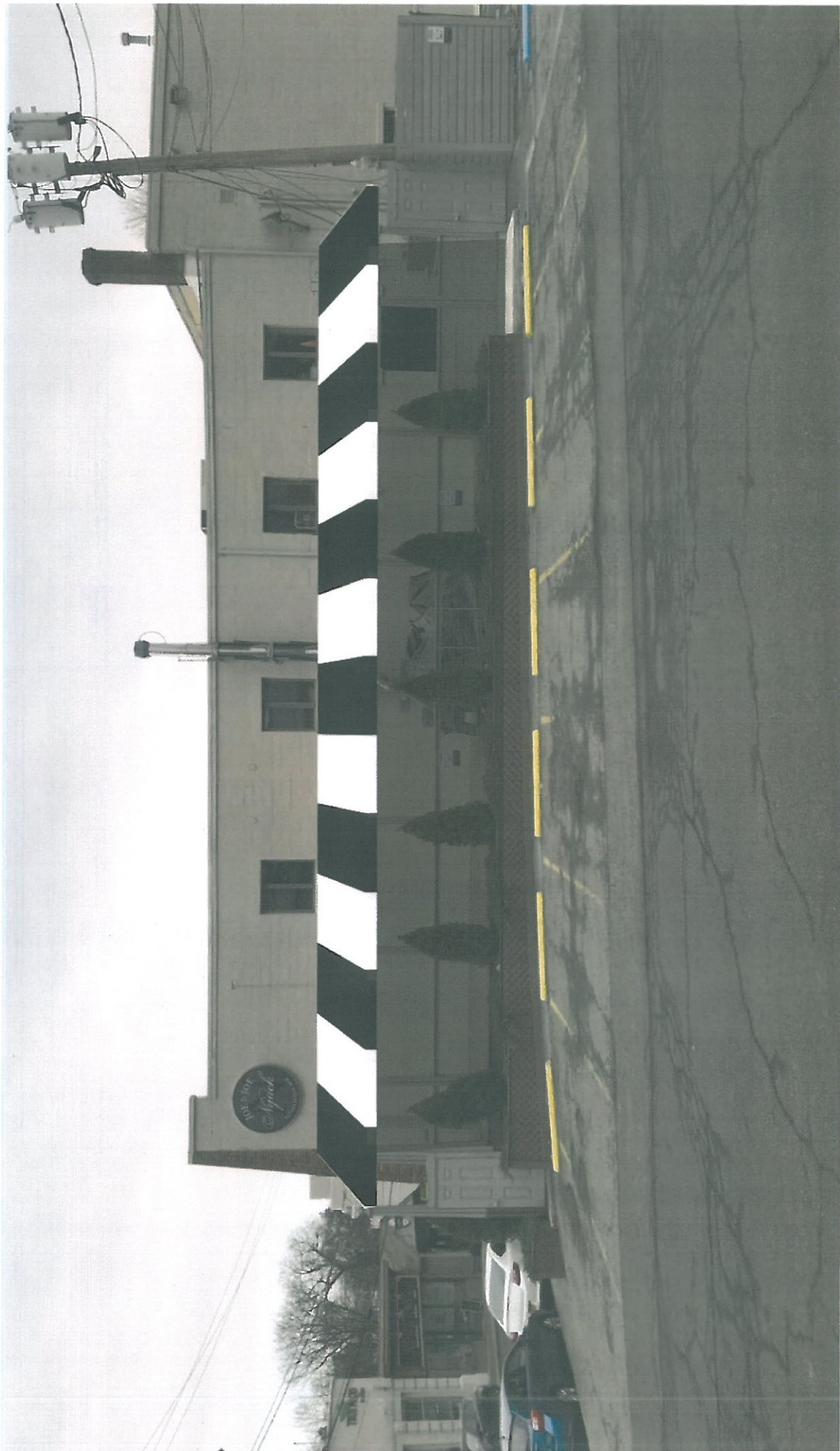

STREET

MAIN STREET

N16-46-56E

173 MAIN ST.

TAX LOT
131-1350-1

(REF.: DEED LIBER 805, PAGE 1082)
GRAVEL PARKING AREA

S16-14-19W

TWO STORY BLOCK BUILDING

TAX LOT
131-1350-2

(REF.: DEED LIBER 805, PAGE 416)
BUILDING ON LINE

S16-22-39W

ONE STORY
BLOCK
BUILDING

TWO STORY
STUCCO BUILDING

N/F
SYLVIA F. WHITE
(REF.: DEED LIBER 850, PAGE 268)

FOUND
IN MICHIGAN

SOFT
SIGN

40.98

N05-50-04W

40.02

CMAA AREA 31.00

LIP SET

OVERHEAD
WIRES

GMS
PUMP

LOADING
DOCK

FEET
SIGN

39.45

S15-59-41E

130.50

C-1

137.58

CONC. SIDEWALK

79.45

ON LINE

11.00

Multi-Tech Engineering, Inc.

834 Wave Drive, Forked River, NJ 08731
(201) - 803-7546 multitech417@gmail.com

Date: January 15, 2021 Revised on 2-8-21

Client: Gregory Sahagian & Son Inc.
18 North Central Ave
Hartsdale, NY 10530

Project: Nyack Grill
Nyack, NY

The proposed Awning meets the following design criteria:

WIND LOADS

All Awning/Canopy frames are designed in accordance with section 1609.0 of the New York State Building Code 2020 Chapter 16 to resist 125 MPH wind pressure from all directions per figure 1609.3 based on geographical location, building classification and exposure rating. Also complies with NY State 2020, Chapter 16, Section BC 1601 Structural Design.

SNOW LOADS

All Awning/Canopy frames are designed in accordance with section 1608.0 of the New York State Building Code 2020 Chapter 16 to withstand a 40 lb/sq ft snow load. Snow loading is per figure 1608.2 and is classified as "Ground Snow Loads" which is based on the geographical location. Also complies with NY State 2020 Edition, Chapter 16, Section BC 1601 Structural Design.

LIVE LOADS

All Awning/Canopy frames are designed in accordance with section 1607.0 of the New York State Building Codes 2020 Chapter 16 to withstand a 35 lb/sq ft live load. Also complies with NY State 2020 Edition, Chapter 16, Section BC 1601 Structural Design.

I hereby certify that this report, calculations, and/or evaluations has been prepared by me or under my direct supervision and that I am a duly licensed engineer under the laws of the States of New Jersey, New York and Pennsylvania.

Ronald R. Sydoruk, P.E.
Professional Engineer
NJ License # 24GE03128600
NY License # 079152
PA License # PE-035473-E



2-8-21



Certificate Of Flame Resistance



REGISTERED
APPLICATION
CONCERN No.

F-73101

ISSUED BY

Glen Raven Custom Fabrics, LLC
1831 North Park Avenue
Glen Raven, NC 27217-1100

Date Work Performed

This is to certify that the materials described at the bottom hereof have been flame-retardant treated (or are inherently nonflammable).

FOR TRI VANTAGE®, LLC AT 1937 WEST 25th STREET
CITY CLEVELAND STATE OHIO 44113

Certification is hereby made that: (Check "a" or "b")

- (a) The articles described at the bottom of this Certificate have been treated with a flame-retardant chemical approved and registered by the State Fire Marshal and that the application of said chemical was done in conformance with the laws of the State of California and the Rules and Regulations of the State Fire Marshal.

Name of chemical used _____ Chem. Reg. No. _____
Method of application _____

- (b) The articles described at the bottom hereof are made from a flame-resistant fabric or material registered and approved by the State Fire Marshal for such use.

Trade name of flame-resistant fabric or material used _____ Firesist _____ Reg. No. F-73101

The Flame Retardant Process Used _____ will not _____ Be Removed By Washing
(will or will not)

Glen Raven Custom Fabrics, LLC
Name of Production Superintendent

By Wendy Miller, Customs Compliance Mgr.
QC Manager

We hereby certify this to be a true copy of the original "CERTIFICATE OF FLAME RESISTANCE" issued to us, "original copy" of which has been filed with the California State Fire Marshal.

TRI VANTAGE, LLC

BY

Albert E. Johnson

Control/lot #
Customer order #
Tri Vantage, LLC Invoice #

Quantity
Description Firesist 60" 8.750Z
Product Code



PROPOSAL
GREGORY SAHAGIAN
& SON AWNING COMPANY INC.

Member of
 Industrial Fabrics Assoc. International
 American Institute of Architects WHV
 Professional Awning Manufacturers Assoc.
 North East Canvas Products Assoc.
 National Federation of Independent Business

In Westchester County at:
 18 N Central Avenue
 PO Box 171
 Hartsdale, NY 10530

914-949-9877 FAX: 914-761-6525
www.gssawning.com
info@gssawning.com

INVOICE TO Bonnie Briar		PROJECT NAME Driving Range Awning			
STREET 808 Weaver Street		STREET			
CITY, STATE, ZIP CODE Larchmont, NY 10538		CITY, STATE, ZIP CODE			
PHONE(S) 914-834-0992	CONTACT	FAX	E-MAIL Joe.Napolitano@bonniebriar.org		
FRAME COLOR TBD	PATTERN #	FABRIC BRAND Sunbrella	PATTERN NAME	VALANCE N/A	BRAID N/A

The manufacture and installation of two (2) cantilevered driving range canopy to replace existing damaged by Hurricane Isaias. There will be four posts at rear to allow for clear span in the front; footings by others, not included. Frames to be constructed from 2 x 2 square and rectangular tubing welded together and powder coated to RAL of choice. Cover to be made from Sunbrella fabric heat sealed together to provide waterproof seams. Frame is designed for seasonal use only and is not rated for a snow load; fabric must be removed during winter months. NYS licensed engineer stamped drawing to be provided upon acceptance of contract. Permit / permit fees if needed, not included; by others.

VILLAGE OF NYACK
 BUILDING
 FEB 09 2021
 DEPARTMENT
 RECEIVED

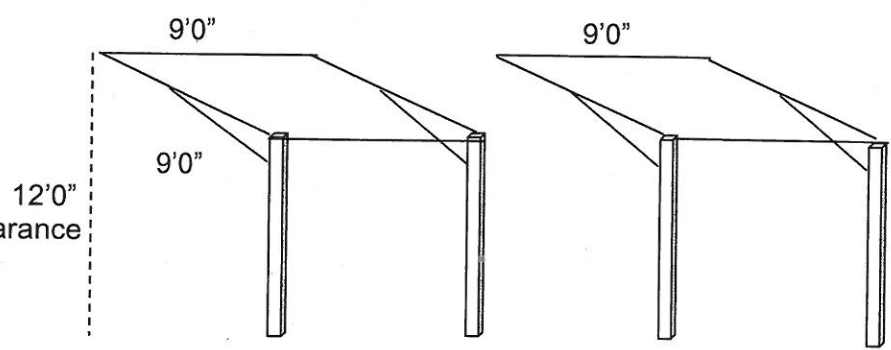

*Must be final field measured upon acceptance of contract.
Please allow 8 – 10 weeks for delivery / installation.

THIS IS A LUMP SUM CONTRACT UNLESS OTHERWISE STATED.
 We Propose hereby to furnish material and labor as described above.
 Please note price does not include state sales tax (if applicable).
 Electrical connection (if needed) not included.

PRICE	\$10,221.00
TAX	+Sales Tax
ENGINEERING	\$1,000.00
TOTAL	\$11,221.00
DEPOSIT	
BAL DUE	\$

Sales Person: Gregory Sahagian Date 9/18/2020
 Gregory Sahagian & Son, Inc. by: _____ Date _____
 Payment _____
 Terms **50% Deposit & Balance Due Upon Completion**

CANVAS AND VINYL AWNINGS WILL WRINKLE.
Acceptance of Proposal- The above prices, specifications and conditions are satisfactory and are hereby accepted. You are authorized to do the work as specified. Payment will be made as outlined above.

PRINT NAME _____
 SIGNATURE _____ DATE _____

SERVING THE TRI-STATE AREA SINCE 1990
 LIC #WC-10266-H99

• The "TERMS AND CONDITIONS OF THIS SALE" accompany, and are part of, this proposal •
PLEASE RETURN SIGNED ORIGINAL UPON ACCEPTANCE



PROPOSAL
GREGORY SAHAGIAN
& SON AWNING COMPANY INC.

Member of
 Industrial Fabrics Assoc. International
 American Institute of Architects WHV
 Professional Awning Manufacturers Assoc.
 North East Canvas Products Assoc.
 National Federation of Independent Business

In Westchester County at:
 18 N Central Avenue
 PO Box 171
 Hartsdale, NY 10530

914-949-9877 FAX: 914-761-6525
www.gssawning.com
info@gssawning.com

INVOICE TO Bonnie Briar			PROJECT NAME Driving Range Awning		
STREET 808 Weaver Street			STREET		
CITY, STATE, ZIP CODE Larchmont, NY 10538			CITY, STATE, ZIP CODE		
PHONE(S) 914-834-0992		CONTACT		FAX	E-MAIL Joe.Napolitano@bonniebriar.org
FRAME COLOR TBD	PATTERN #	FABRIC BRAND Sunbrella	PATTERN NAME		VALANCE N/A
					BRAID N/A

The manufacture and installation of two (2) cantilevered driving range canopy to replace existing damaged by Hurricane Isaias. There will be four posts at rear to allow for clear span in the front; footings by others, not included. Frames to be constructed from 2 x 2 square and rectangular tubing welded together and powder coated to RAL of choice. Cover to be made from Sunbrella fabric heat sealed together to provide waterproof seams. Frame is designed for seasonal use only and is not rated for a snow load; fabric must be removed during winter months. NYS licensed engineer stamped drawing to be provided upon acceptance of contract. Permit / permit fees if needed, not included; by others.

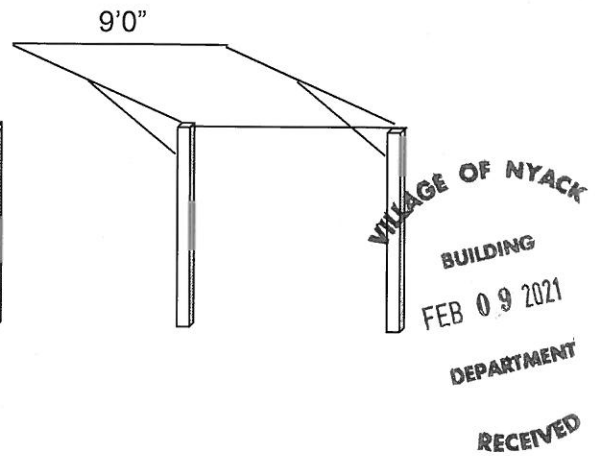
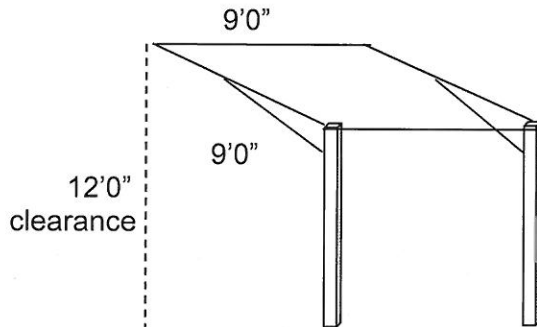

*Must be final field measured upon acceptance of contract.
Please allow 8 – 10 weeks for delivery / installation.

THIS IS A LUMP SUM CONTRACT UNLESS OTHERWISE STATED.
 We Propose hereby to furnish material and labor as described above.
 Please note price does not include state sales tax (if applicable).
 Electrical connection (if needed) not included.

PRICE	\$10,221.00
TAX	+Sales Tax
ENGINEERING	\$1,000.00
TOTAL	\$11,221.00
DEPOSIT	
BAL DUE	\$

Sales Person: Gregory Sahagian Date 9/18/2020
 Gregory Sahagian & Son, Inc. by: _____ Date _____
 Payment _____
 Terms **50% Deposit & Balance Due Upon Completion**

CANVAS AND VINYL AWNINGS WILL WRINKLE.
Acceptance of Proposal- The above prices, specifications and conditions are satisfactory and are hereby accepted. You are authorized to do the work as specified. Payment will be made as outlined above.

PRINT NAME _____
 SIGNATURE _____ DATE _____

SERVING THE TRI-STATE AREA SINCE 1990
 LIC #WC-10266-H99

• The "TERMS AND CONDITIONS OF THIS SALE" accompany, and are part of, this proposal •
PLEASE RETURN SIGNED ORIGINAL UPON ACCEPTANCE

Multi-Tech Engineering, Inc.

834 Wave Drive, Forked River, NJ 08731
(201) - 803-7546 multitech417@gmail.com

Date: January 15, 2021 Revised on 2-8-21

Client: Gregory Sahagian & Son Inc.
18 North Central Ave
Hartsdale, NY 10530

Project: Nyack Grill
Nyack, NY



The proposed Awning meets the following design criteria:

WIND LOADS

All Awning/Canopy frames are designed in accordance with section 1609.0 of the New York State Building Code 2020 Chapter 16 to resist 125 MPH wind pressure from all directions per figure 1609.3 based on geographical location, building classification and exposure rating. Also complies with NY State 2020, Chapter 16, Section BC 1601 Structural Design.

SNOW LOADS

All Awning/Canopy frames are designed in accordance with section 1608.0 of the New York State Building Code 2020 Chapter 16 to withstand a 40 lb/sq ft snow load. Snow loading is per figure 1608.2 and is classified as "Ground Snow Loads" which is based on the geographical location. Also complies with NY State 2020 Edition, Chapter 16, Section BC 1601 Structural Design.

LIVE LOADS

All Awning/Canopy frames are designed in accordance with section 1607.0 of the New York State Building Codes 2020 Chapter 16 to withstand a 35 lb/sq ft live load. Also complies with NY State 2020 Edition, Chapter 16, Section BC 1601 Structural Design.

I hereby certify that this report, calculations, and/or evaluations has been prepared by me or under my direct supervision and that I am a duly licensed engineer under the laws of the States of New Jersey, New York and Pennsylvania.

Ronald R. Sydoruk, P.E.
Professional Engineer
NJ License # 24GE03128600
NY License # 079152
PA License # PE-035473-E

A handwritten signature in black ink, appearing to be "R. Sydoruk". Below the signature, the date "2-8-21" is written.



Certificate Of Flame Resistance



REGISTERED
APPLICATION
CONCERN No.

F-73101

ISSUED BY

Glen Raven Custom Fabrics, LLC
1831 North Park Avenue
Glen Raven, NC 27217-1100

Date Work Performed

This is to certify that the materials described at the bottom hereof have been flame-retardant treated (or are inherently nonflamable).

FOR TRI VANTAGE®, LLC AT 1937 WEST 25th STREET
CITY CLEVELAND STATE OHIO 44113

Certification is hereby made that: (Check "a" or "b")

- (a) The articles described at the bottom of this Certificate have been treated with a flame-retardant chemical approved and registered by the State Fire Marshal and that the application of said chemical was done in conformance with the laws of the State of California and the Rules and Regulations of the State Fire Marshal.

Name of chemical used _____ Chem. Reg. No. _____
Method of application _____

- (b) The articles described at the bottom hereof are made from a flame-resistant fabric or material registered and approved by the State Fire Marshal for such use.

Trade name of flame-resistant fabric or material used _____ Firesist _____ Reg. No. F-73101

The Flame Retardant Process Used will not Be Removed By Washing
(will or will not)

Glen Raven Custom Fabrics, LLC By Wendy Miller, Customs Compliance Mgr.
Name of Production Superintendent QC Manager

VILLAGE OF NYACK

BUILDING

FEB 09 2021

DEPARTMENT

RECEIVED

We hereby certify this to be a true copy of the original "CERTIFICATE OF FLAME RESISTANCE" issued to us, "original copy" of which has been filed with the California State Fire Marshal.

TRI VANTAGE, LLC

BY

Albert E. Johnson

Control/lot #
Customer order #
Tri Vantage, LLC Invoice #

Quantity
Description Firesist 60" 8.750Z
Product Code